



SERVICE PARTS LIST

BULLETIN NO.
54-06-2610

SPECIFY CATALOG NO. AND SERIAL NO. WHEN ORDERING PARTS		REVISED BULLETIN	DATE
1/2" Compact Driver Drill			Mar. 2009
CATALOG NO. 2601-20	STARTING SERIAL NO. B28A	WIRING INSTRUCTION SEE REVERSE SIDE	

00 0

EXAMPLE:
Component Parts (Small #) Are Included When Ordering The Assembly (Large #).

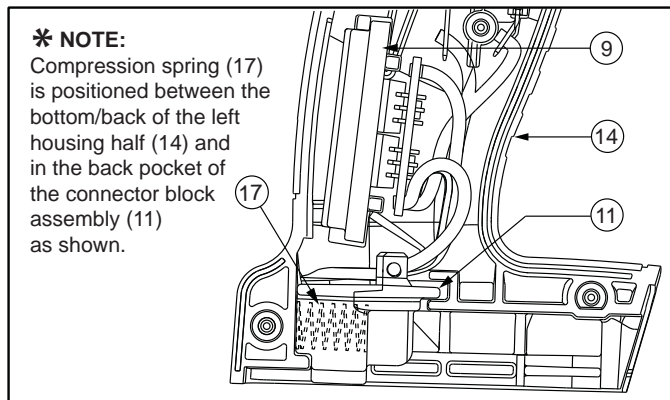
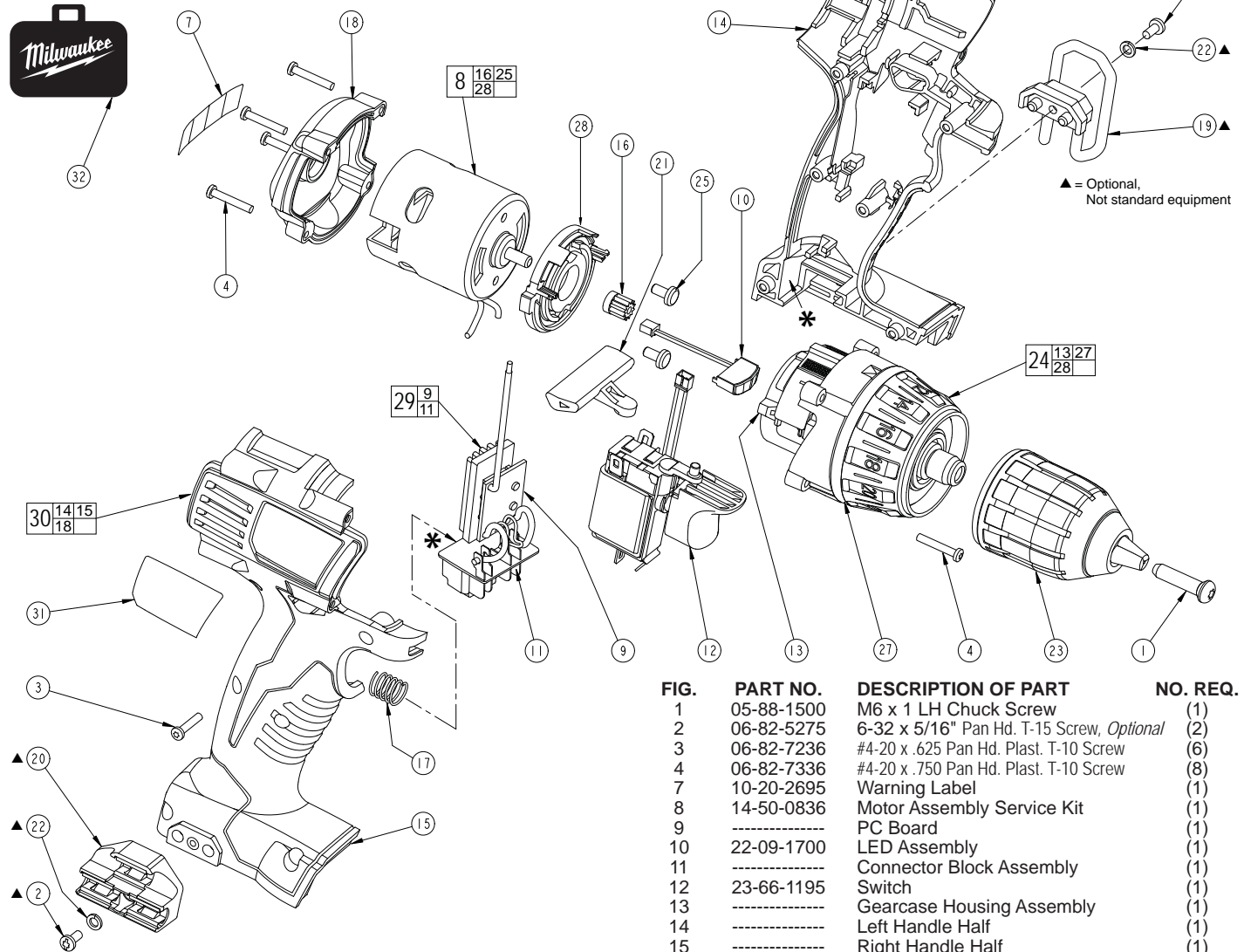
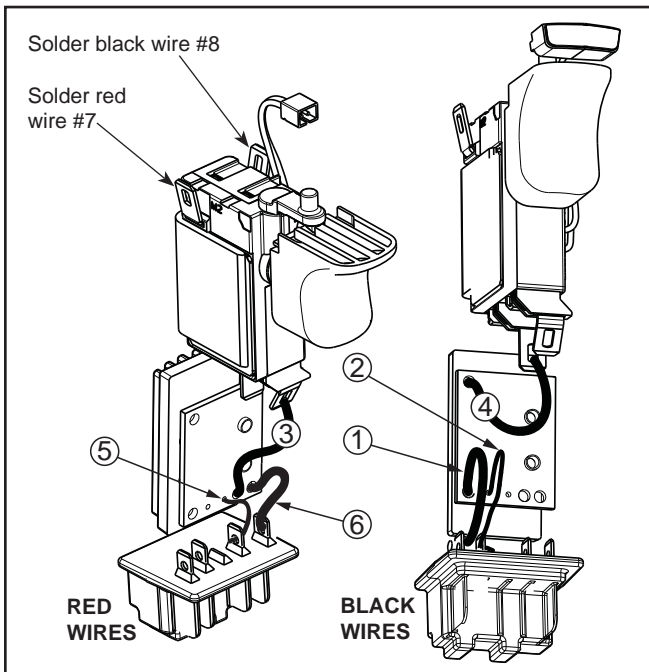
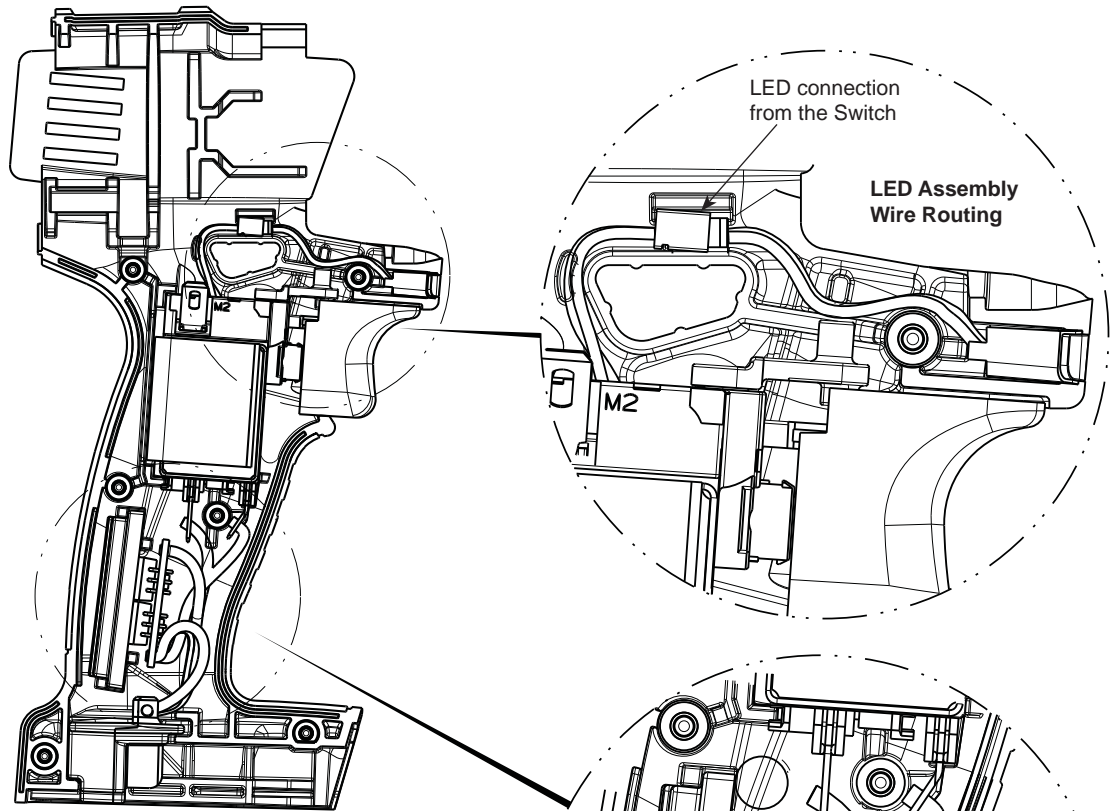

FIG.	PART NO.	DESCRIPTION OF PART	NO. REQ.
1	05-88-1500	M6 x 1 LH Chuck Screw	(1)
2	06-82-5275	6-32 x 5/16" Pan Hd. T-15 Screw, <i>Optional</i>	(2)
3	06-82-7236	#4-20 x .625 Pan Hd. Plast. T-10 Screw	(6)
4	06-82-7336	#4-20 x .750 Pan Hd. Plast. T-10 Screw	(8)
7	10-20-2695	Warning Label	(1)
8	14-50-0836	Motor Assembly Service Kit	(1)
9	-----	PC Board	(1)
10	22-09-1700	LED Assembly	(1)
11	-----	Connector Block Assembly	(1)
12	23-66-1195	Switch	(1)
13	-----	Gearcase Housing Assembly	(1)
14	-----	Left Handle Half	(1)
15	-----	Right Handle Half	(1)
16	-----	Pinion Gear	(1)
17	40-50-1090	Compression Spring	(1)
18	42-52-0290	Housing End Cap	(1)
19	42-70-5150	Belt Hook, <i>Optional</i>	(1)
20	43-72-0550	Bit Holder, <i>Optional</i>	(1)
21	45-24-0900	Forward/Reverse Lever	(1)
22	45-88-1935	Washer, <i>Optional</i>	(1)
23	48-66-1275	Chuck Assembly	(1)
24	28-14-0660	Gearcase Assembly Service Kit	(1)
25	-----	M5 x 8mm Pan Head Screw	(2)
27	-----	Torque Selector Ring	(1)
28	-----	Motor Mount	(1)
29	22-56-1230	PCB/Connector Block Assembly	(1)
30	31-44-2360	Handle Assembly Service Kit	(1)
31	12-20-0800	Service Nameplate	(1)
32	48-55-0960	Accessory Carrying Case	(1)

FIG. 8, 24, 28 **NOTES:**
Service replacement gearcase assembly (24) comes with a motor mount plate (28) that must be removed and discarded when servicing. A motor mount plate already exists on the motor assembly (8).

WIRING INSTRUCTIONS



Connector Block:
Hook wires ,
then solder.

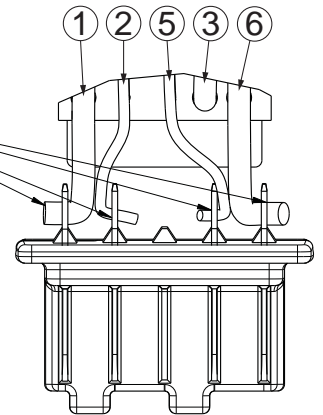

WIRING SPECIFICATIONS

Wire No.	Wire Color	Origin or Gauge	Length	Terminals, Connectors and 1 or 2 End Wire Preparation
1	Black	----	----	Component of the Connector Block Assembly.
2	Black	----	----	Component of the Connector Block Assembly.
3	Red	----	----	Component of the Connector Block Assembly.
4	Black	----	----	Component of the Connector Block Assembly.
5	Red	----	----	Component of the Connector Block Assembly.
6	Red	----	----	Component of the Connector Block Assembly.
7	Red	----	----	Component of the Motor Assembly.
8	Black	----	----	Component of the Motor Assembly.