

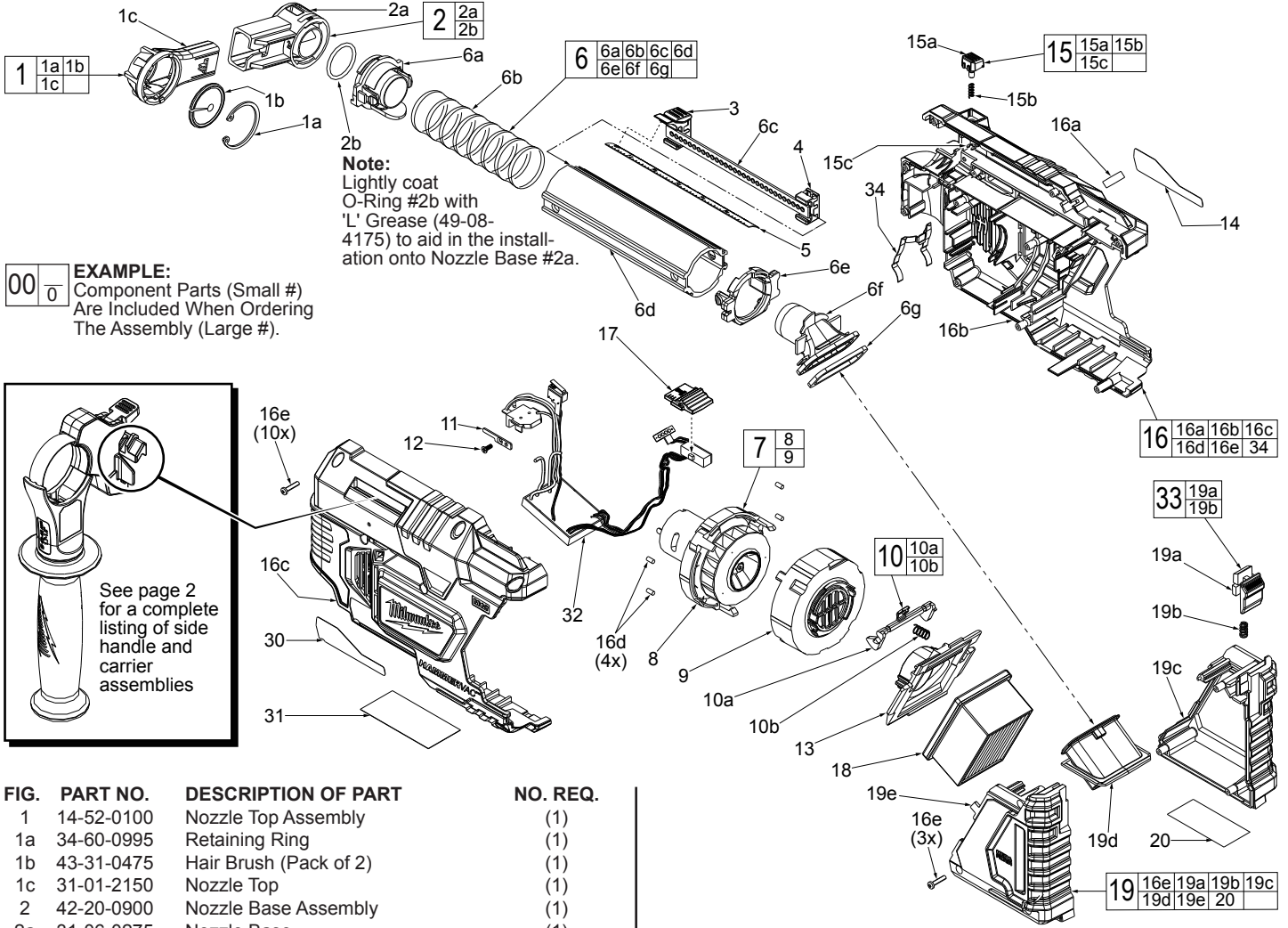

SERVICE PARTS LIST

BULLETIN NO.
54-05-0010

SPECIFY CATALOG NO. AND SERIAL NO. WHEN ORDERING PARTS		REVISED BULLETIN	DATE
M12™ HammerVAC™ Dust Extractor			Dec. 2012
CATALOG NO.	2306-20	SERIAL NUMBER	E82A
			WIRING INSTRUCTION See Page 3



EXAMPLE:
Component Parts (Small #)
Are Included When Ordering
The Assembly (Large #).

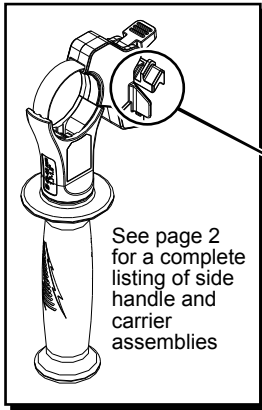
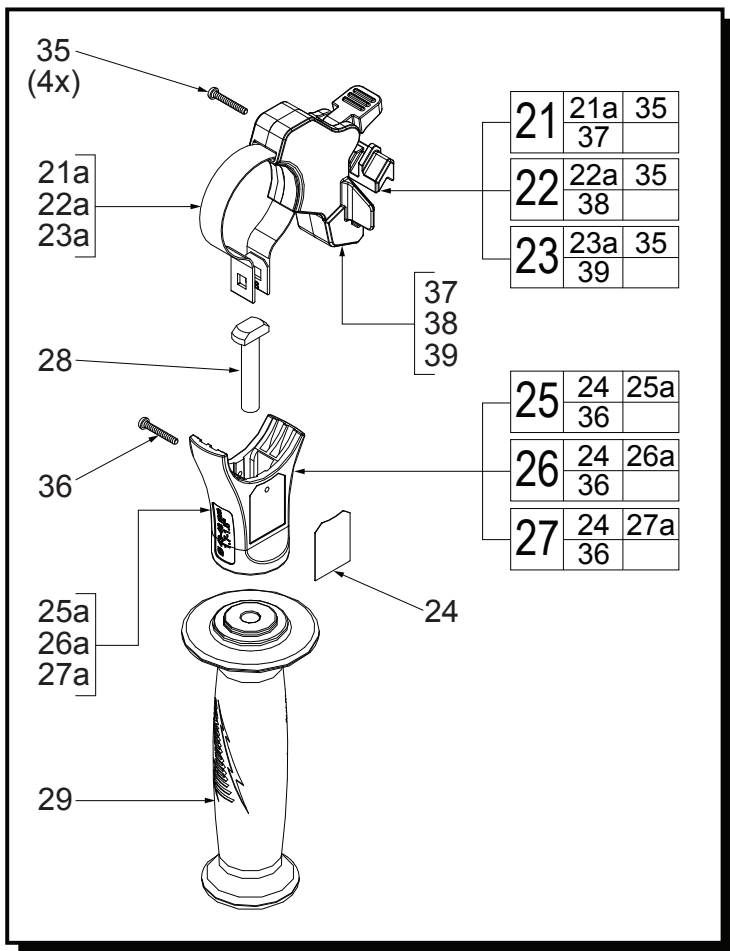

FIG.	PART NO.	DESCRIPTION OF PART	NO. REQ.
1	14-52-0100	Nozzle Top Assembly	(1)
1a	34-60-0995	Retaining Ring	(1)
1b	43-31-0475	Hair Brush (Pack of 2)	(1)
1c	31-01-2150	Nozzle Top	(1)
2	42-20-0900	Nozzle Base Assembly	(1)
2a	31-06-0275	Nozzle Base	(1)
2b	34-40-0990	O-Ring - Nozzle	(1)
3	42-42-1175	Depth Stop Button Assembly	(1)
4	42-42-1375	Bit Length Adjustment Button Assembly	(1)
5	31-51-0150	Movable Ruler	(1)
6	45-76-1050	Extension Tube Assembly	(1)
6a	31-12-0710	Tube Cap - Front	(1)
6b	45-76-0750	Spring Tube	(1)
6c	44-81-0100	Tube Track	(1)
6d	42-30-0440	Tube Body	(1)
6e	31-12-0720	Tube Cap - Rear	(1)
6f	31-05-0740	Dust Outlet	(1)
6g	43-44-1400	Gasket	(1)
7	14-50-2000	Fan and Motor Assembly	(1)
8	45-60-0900	Fan Support Assembly	(1)
9	31-15-1040	Fan Cover Assembly with Gasket	(1)
10	44-10-0925	Filter Finger and Spring Assembly	(1)
10a	31-52-0340	Filter Finger	(1)
10b	40-50-1190	Spring	(1)
11	44-66-1390	Metal Plate	(1)
12	05-81-1100	M2.6 x 5mm Screw	(1)
13	45-60-0840	Finger Support	(1)
14	10-20-4308	Warning Label	(1)
15	42-42-1300	Clip and Button Assembly	(1)
15a	42-42-1180	Rear Release Button	(1)
15b	40-50-1820	Spring	(1)
15c	44-90-0990	C-Ring	(1)
16	14-38-1150	Housing Assembly	(1)
16a	10-20-4335	Fuel Gauge Label	(1)

FIG.	PART NO.	DESCRIPTION OF PART	NO. REQ.
16b	45-60-0820	Motor Housing Support	(1)
16c	31-15-1230	Motor Housing Cover	(1)
16d	45-30-0250	Rubber Cushion	(4)
16e	05-81-1325	M3 x 14mm Pan Hd. Plast. T-10 Screw	(13)
17	42-42-1190	3 Position Slide Button	(1)
18	49-90-2306	Filter (Pack of 3)	(1)
19	42-16-0650	Dust Box Assembly	(1)
19a	42-42-2000	Dust Box Release Button	(1)
19b	40-50-2160	Spring	(1)
19c	31-15-1240	Dust Box Cover	(1)
19d	42-96-0460	Dust Box Entrance	(1)
19e	45-60-0830	Dust Box Support	(1)
20	10-20-4342	Dust Box Label	(1)
30	12-20-2306	Service Nameplate	(1)
31	10-20-4348	Tri-lingual Warning Label	(1)
32	22-06-0300	PCBA Assembly	(1)
33	42-42-2005	Release Button Assembly	(1)
34	42-70-0480	Spring Clip	(1)



SMALL HANDLE CARRIER ASSEMBLY

FIG.	PART NO.	DESCRIPTION OF PART	NO. REQ.
21	14-48-0200	Handle Carrier Assembly - Small	(1)
21a	44-90-1120	Locking Ring - Small	(1)
35	05-81-1300	M3 x 10mm Pan Hd. T-10 Screw	(4)
37	-----	Handle Carrier - Small	(1)

MEDIUM HANDLE CARRIER ASSEMBLY

FIG.	PART NO.	DESCRIPTION OF PART	NO. REQ.
22	14-48-0250	Handle Carrier Assembly - Medium	(1)
22a	44-90-1140	Locking Ring - Medium	(1)
35	05-81-1300	M3 x 10mm Pan Hd. T-10 Screw	(4)
38	-----	Handle Carrier - Medium	(1)

LARGE HANDLE CARRIER ASSEMBLY

FIG.	PART NO.	DESCRIPTION OF PART	NO. REQ.
23	14-48-0275	Handle Carrier Assembly - Large	(1)
23a	44-90-1160	Locking Ring - Large	(1)
35	05-81-1300	M3 x 10mm Pan Hd. T-10 Screw	(4)
39	-----	Handle Carrier - Large	(1)

SMALL HANDLE HOUSING ASSEMBLY

FIG.	PART NO.	DESCRIPTION OF PART	NO. REQ.
24	10-20-4344	Side Handle Warning Label	(1)
25	14-34-1020	Handle Housing Assembly - Small	(1)
25a	43-76-0830	Handle Housing - Small	(1)
36	05-88-0780	M3 x .75 Pan Hd. Plastite T-10 Screw	(1)

MEDIUM HANDLE HOUSING ASSEMBLY

FIG.	PART NO.	DESCRIPTION OF PART	NO. REQ.
24	10-20-4344	Side Handle Warning Label	(1)
26	14-34-1040	Handle Housing Assembly - Medium	(1)
26a	43-76-0840	Handle Housing - Medium	(1)
36	05-88-0780	M3 x .75 Pan Hd. Plastite T-10 Screw	(1)

LARGE HANDLE HOUSING ASSEMBLY

FIG.	PART NO.	DESCRIPTION OF PART	NO. REQ.
24	10-20-4344	Side Handle Warning Label	(1)
27	14-34-1060	Handle Housing Assembly - Large	(1)
27a	43-76-0860	Handle Housing - Large	(1)
36	05-88-0780	M3 x .75 Pan Hd. Plastite T-10 Screw	(1)

FIG.	PART NO.	DESCRIPTION OF PART	NO. REQ.
28	42-32-0840	T-Bolt	(1)
29	31-05-5379	Side Handle	(1)

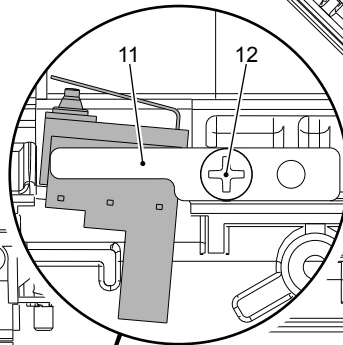
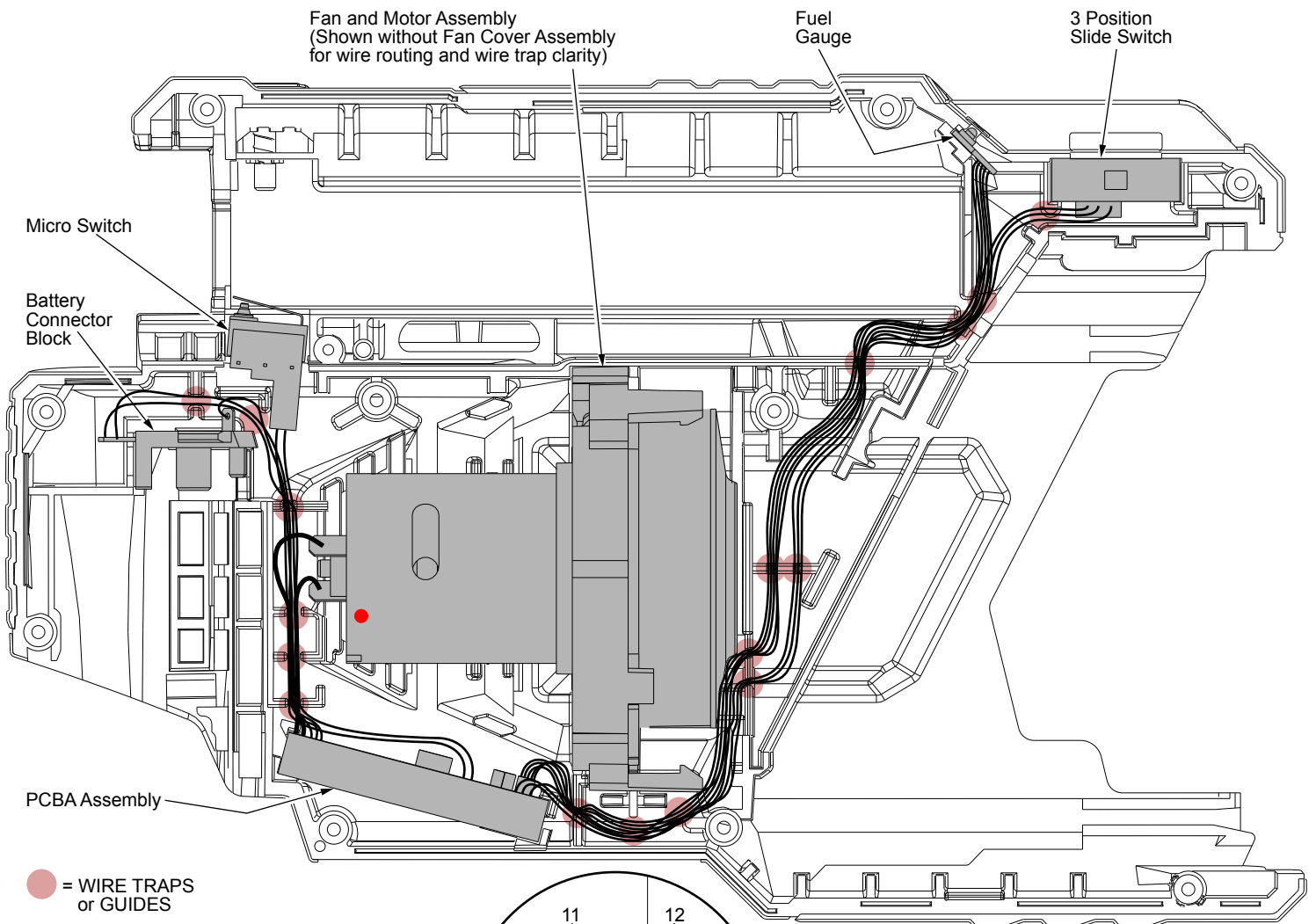

Metal Plate #11 and
Screw #12 secure Micro Switch
in Motor Housing Support #16b

**WIRE ROUTING THROUGH THE
MOTOR HOUSING SUPPORT**

Route the five PCBA / Fuel Gauge wires
through wire traps 7, 8, 9, 11, 12, 14, 15
and 16.

Route the three PCBA / Slide Switch wires
through wire traps 7, 8, 9, 10, 13, 14, 15,
16 and 17.

Route the two PCBA / Micro Switch wires
through wire traps 6, 5, 4 and 3.

Route the black PCBA / Battery
Connector Block wire through
wire traps 6, 5, 4, 3, 2 and 1.

Route the white PCBA / Battery
Connector Block wire through
wire traps 6, 5, 4 and 3.

Route the red PCBA / Battery
Connector Block wire through
wire traps 6, 5, 4, 3, 2 and 1.

Route the black and white PCBA / Motor
wires through wire traps 6, 5 and 4.

**Be sure to position the motor with the positive
terminal (red dot) facing outward as shown.
White PCBA wire to the positive terminal.**

