

WIRING INSTRUCTIONS

TITLE	BODY GRIP TOOLS	BULLETIN
MILWAUKEE ELECTRIC TOOL CORP. 13135 WEST LISBON RD. BROOKFIELD, WIS.	DATE Feb. '95	58-01-0308

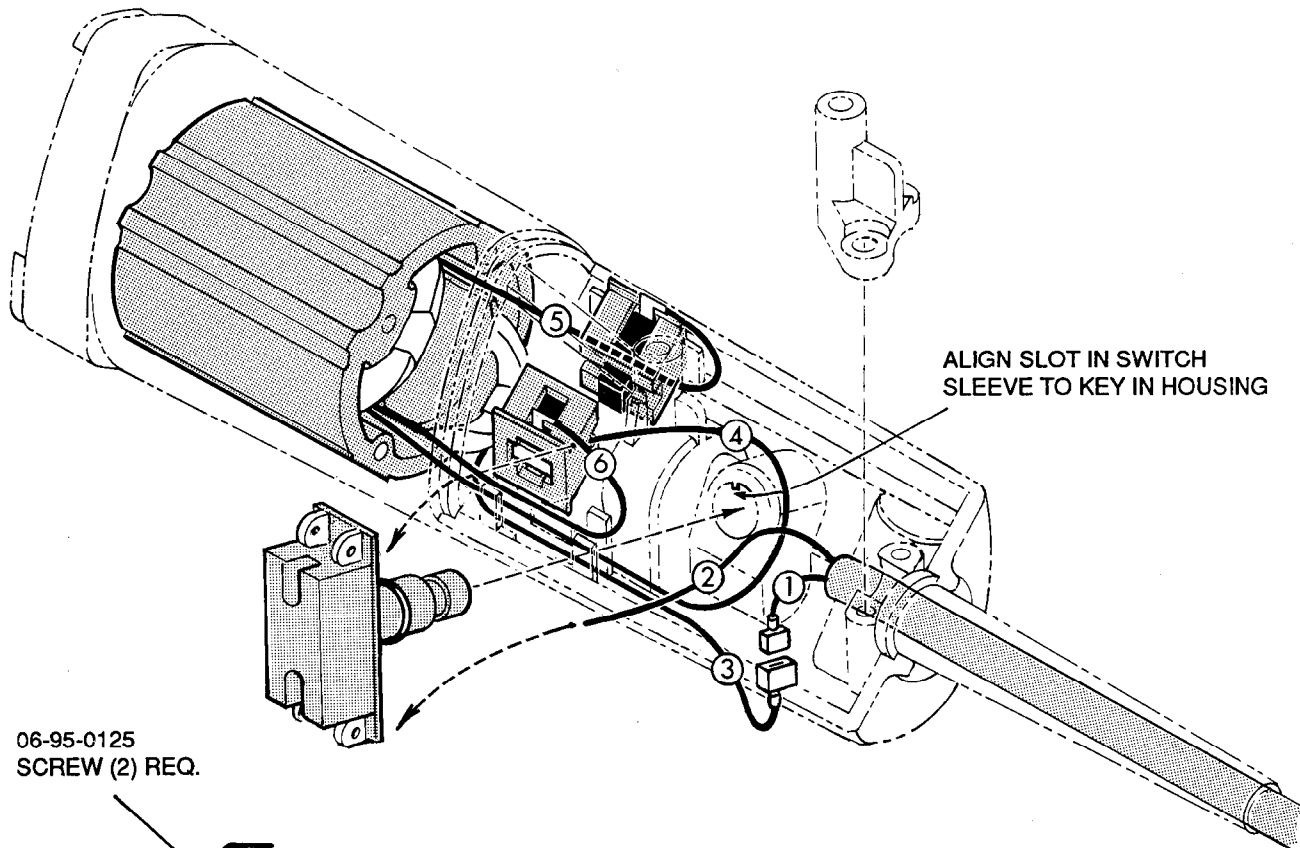

ALIGN SLOT IN SWITCH SLEEVE TO KEY IN HOUSING

06-95-0125
SCREW (2) REQ.

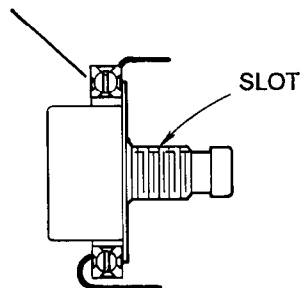

WIRE ROUTING DETAIL AT SWITCH TERMINALS

NOTE:
PULL SLIGHTLY ON LEADS AFTER CRIMPING TO TEST THE CRIMP

PUSH BUTTON SWITCH SHOWN (SOME TOOLS HAVE TOGGLE SWITCH). WIRING HOOKUP IS COMMON TO BOTH. POSITION TOGGLE SWITCH SO THAT THE "ON" MARKING OF THE SWITCH CORRESPONDS TO THE "ON" MARKING OF THE TRIGGER COVER.

WIRING SPECIFICATIONS

Wire No.	Wire Color	Origin or Part No.	Gauge	Length	Terminals, Connectors and End Wire Preparation
1	White	Cord	18	2"	Cut & Strip 3/16" for T2 (See Note)
2	Black	Cord	18	2"	Cut & Strip 1/4"
3	White	Field	18	-----	Strip 3/16" for T3 (See Note)
4	Blue	Field	18	-----	Strip 1/4"
5	Black	Field	18	-----	Strip 3/16" for T1
6	Black	Field	18	-----	Strip 3/16" for T1

BULK LEAD WIRE - BULLETIN 58-01-0003

NOTE:
All leads must be held to $\pm 1/8"$.
All field leads to be measured from and perpendicular to laminations.
All lead lengths are before stripping.

TERMINAL DESCRIPTION

Code	Part No.	Qty.
T1	23-74-0695	2
T2	23-74-0430	1
T3	23-74-0440	1

TERMINAL DESCRIPTION

Code	Part No.	Qty.