



SERVICE PARTS LIST

BULLETIN NO.
54-26-2660

SPECIFY CATALOG NO. AND SERIAL NO. WHEN ORDERING PARTS		REVISED BULLETIN	DATE
CORDLESS 18V 1/2" SQUARE IMPACT WRENCH			Jan. 2009
CATALOG NO.	2662-20	STARTING SERIAL NO.	B79A
		WIRING INSTRUCTION See Reverse Side	

EXAMPLE:
Component Parts (Small #) Are Included
When Ordering The Assembly (Large #).

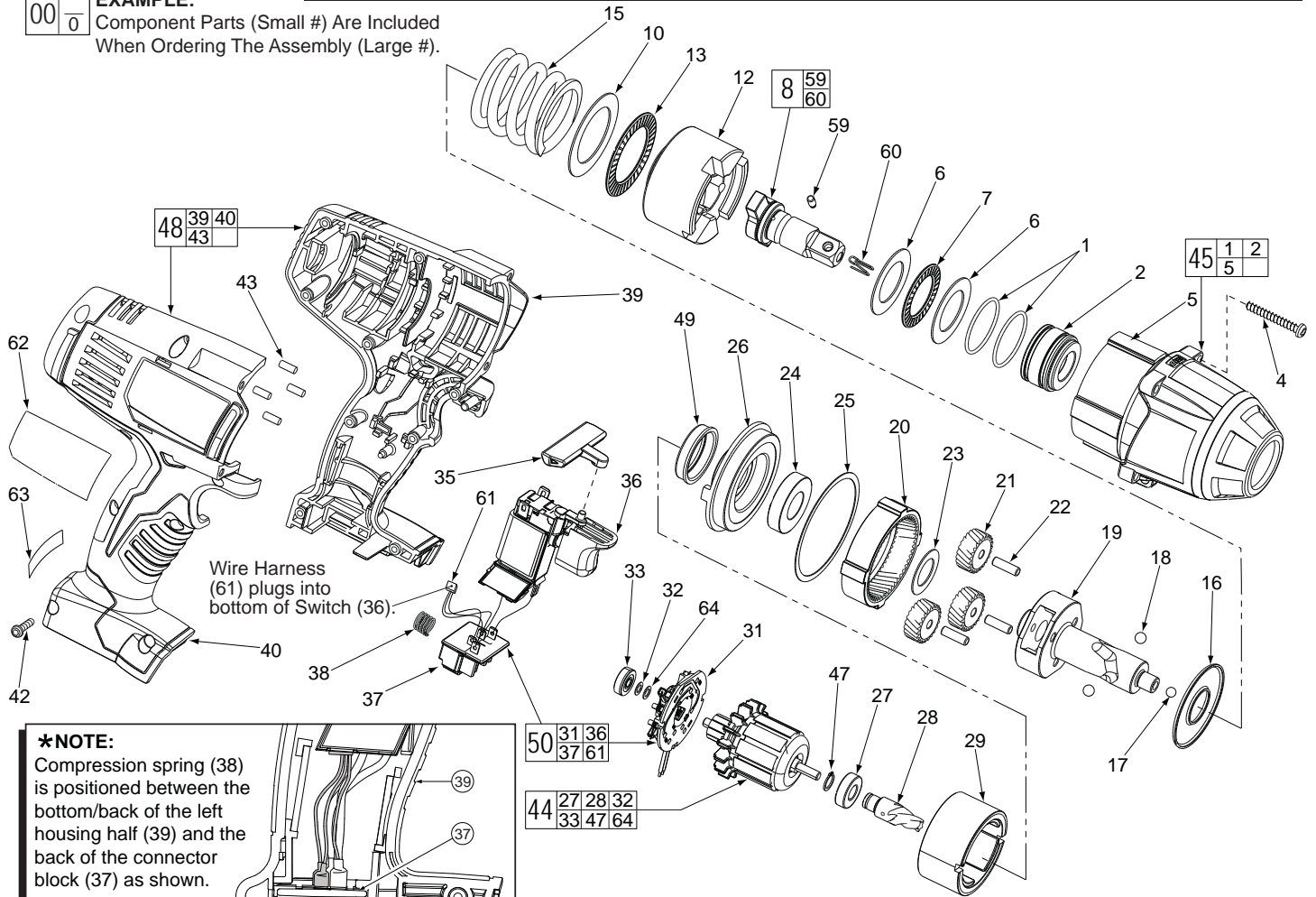

***NOTE:**
Compression spring (38) is positioned between the bottom/back of the left housing half (39) and the back of the connector block (37) as shown.

FIG.	PART NO.	DESCRIPTION OF PART	NO.REQ.
1	-----	O-Ring	(2)
2	-----	Bushing	(1)
4	05-88-5988	M5 X 35mm Pan Hd. Slit. T-20 Screw	(4)
5	-----	Gearcase Housing	(1)
6	45-88-1875	Washer	(2)
7	02-80-3256	Thrust Bearing	(1)
8	42-06-0670	1/2" Anvil with Detent	(1)
10	45-88-1006	Washer	(1)
12	44-82-0275	Ram	(1)
13	02-80-0200	Thrust Bearing	(1)
15	40-50-0755	Compression Spring	(1)
16	45-88-1650	Washer	(1)
17	02-02-7010	7/32" Ball	(1)
18	02-02-0250	1/4" Ball	(2)
19	42-50-0475	Camshaft	(1)
20	32-65-0260	Ring Gear	(1)
21	32-62-0500	Planet Gear	(3)
22	44-60-1960	Pin	(3)
23	45-88-1655	Washer	(1)
24	02-04-0375	Ball Bearing	(1)
25	34-40-0290	Seal Ring	(1)
26	44-66-0895	Motor Mount Plate	(1)
27	-----	Ball Bearing - Front	(1)
28	-----	Pinion	(1)
29	18-01-3025	Service Field Assembly	(1)
31	-----	Brush Card	(1)
32	-----	Washer	(1)
33	-----	Ball Bearing - Rear	(1)
35	45-24-0570	Forward / Reverse Shuttle	(1)

FIG.	PART NO.	DESCRIPTION OF PART	NO.REQ.
36	-----	Switch	(1)
37	-----	Connector Block	(1)
38	40-50-1090	Compression Spring	(1)
39	-----	Handle - Left	(1)
40	-----	Handle - Right	(1)
42	06-82-0995	M4 x 16mm Pan Hd. T-20 Screw	(9)
43	45-30-0255	Rubber Slug	(4)
44	16-01-3030	Armature Assembly	(1)
45	14-30-0870	Front Housing Assembly	(1)
47	-----	Retaining Ring	(1)
48	31-44-0695	Handle Set	(1)
49	45-22-0380	Rubber Cap	(1)
50	22-56-1130	Switch/Connector Block Assembly	(1)
59	44-60-1170	Detent Pin	(1)
60	40-50-8320	Detent Spring	(1)
61	-----	Wire Harness	(1)
62	12-20-2670	Service Nameplate Kit	(1)
63	10-20-2695	Warning Label	(1)
64	-----	Washer	(1)
	42-55-2665	Carrying Case, Optional (Not Shown)	(1)

FIG. LUBRICATION
(Type 'Z' Grease, No. 49-08-7655):
20,21 Lightly coat the I.D. of the Ring Gear (20) and the center of the three Planet Gears (21) with grease.
19 Place a dab of grease in ball grooves of the Cam Shaft (19).
8 Lightly coat the front washer surface of Anvil (8) with grease, place a dab in the Ball hole on the backside of Anvil.
2 Coat outside grooves of Bushing (2) with grease.

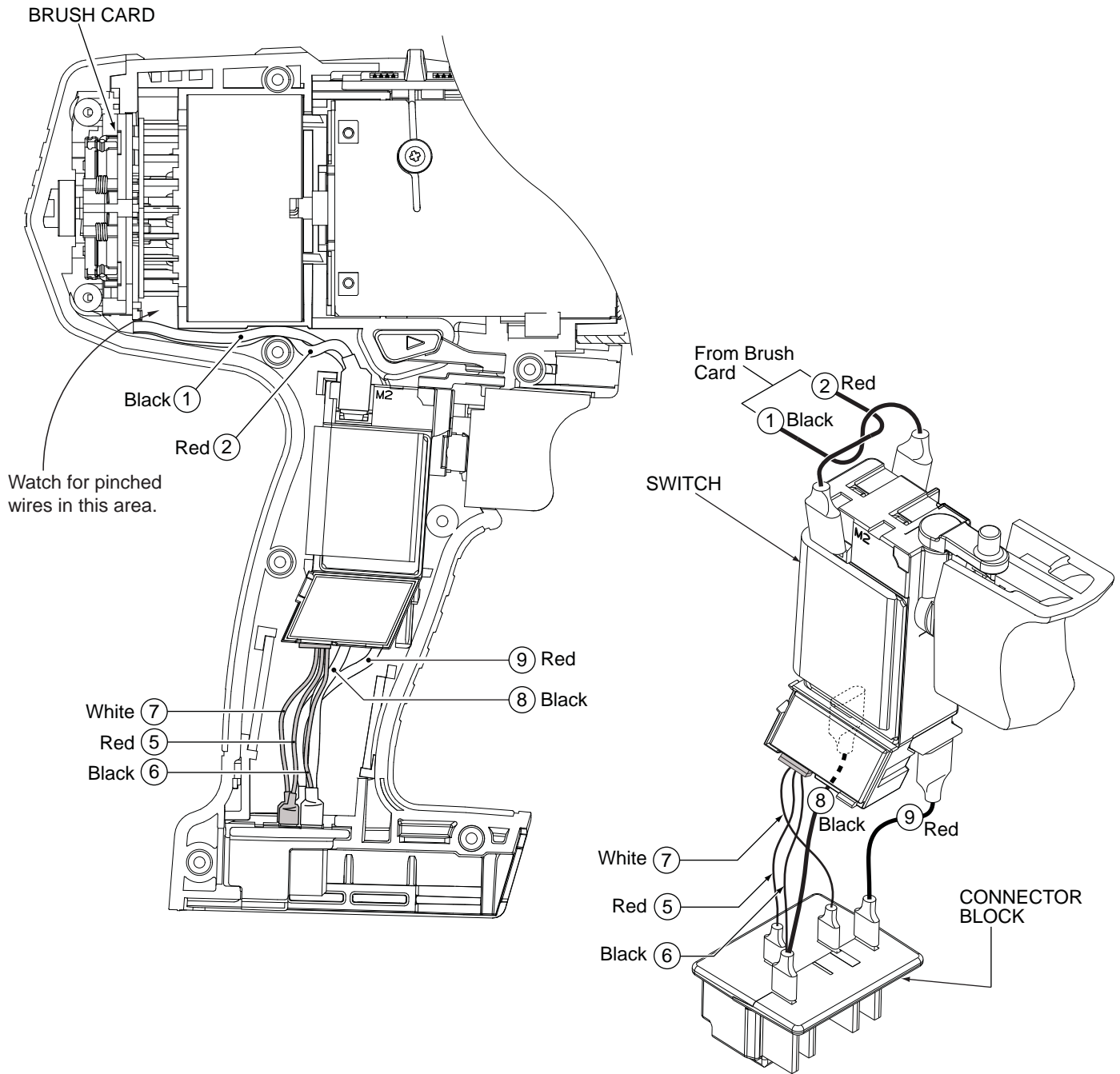

WIRING SPECIFICATIONS

Wire No.	Wire Color	Origin or Gauge	Length	Terminals, Connectors and 1 or 2 End Wire Preparation
1	Black	-----	-----	Component of the Switch/Connector Block Assembly.
2	Red	-----	-----	Component of the Switch/Connector Block Assembly.
5	Red	-----	-----	Component of the Switch/Connector Block Assembly.
6	Black	-----	-----	Component of the Switch/Connector Block Assembly.
7	White	-----	-----	Component of the Switch/Connector Block Assembly.
8	Black	-----	-----	Component of the Switch/Connector Block Assembly.
9	Red	-----	-----	Component of the Switch/Connector Block Assembly.

