



SERVICE PARTS LIST

**BULLETIN NO.
54-08-7000**

SPECIFY CATALOG NO. AND SERIAL NO. WHEN ORDERING PARTS		REVISED BULLETIN	DATE
CORDLESS D-HANDLE RAD			Feb. 2006
CATALOG NO. 0721-20	STARTING SERIAL NO. A73A	WIRING INSTRUCTION SEE REVERSE SIDE	

00
0

EXAMPLE:
Component Parts (Small #)
Are Included When Ordering
The Assembly (Large #).

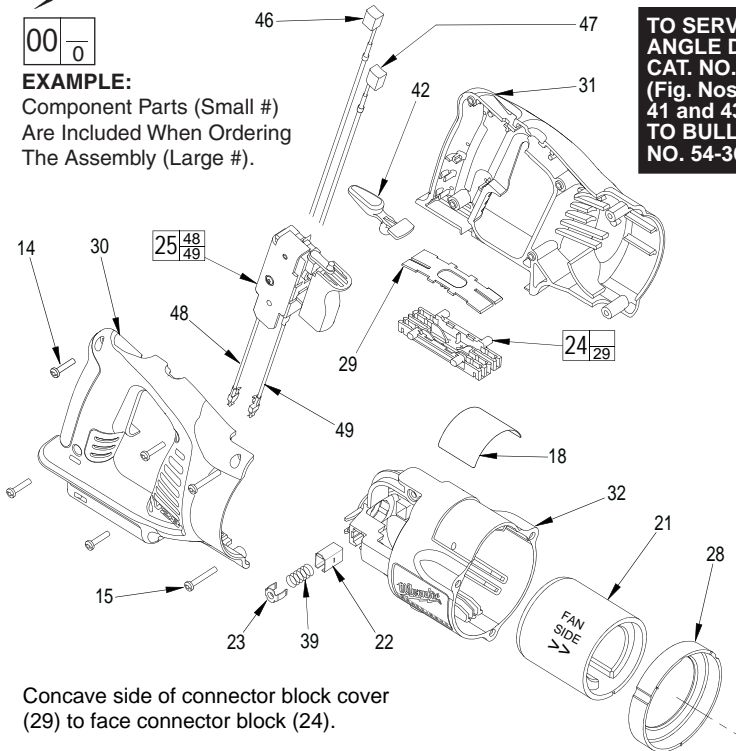

Concave side of connector block cover (29) to face connector block (24).

TO SERVICE RIGHT ANGLE DRIVE UNIT CAT. NO. 48-06-2871 (Fig. Nos. 12, 19, 40, 41 and 43) REFER TO BULLETIN NO. 54-36-0602.

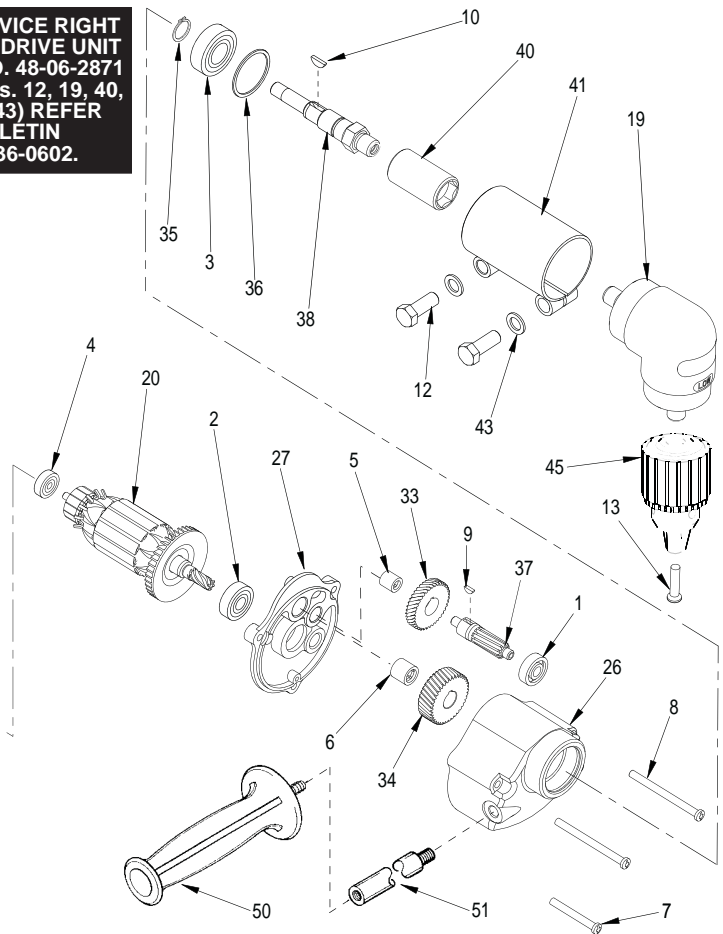

FIG.	PART NO.	DESCRIPTION OF PART	NO. REQ.
1	02-04-0725	Ball Bearing	(1)
2	02-04-0911	Ball Bearing	(1)
3	02-04-1536	Ball Bearing	(1)
4	02-04-5130	Ball Bearing	(1)
5	02-50-1640	Needle Bearing	(1)
6	02-50-2440	Needle Bearing	(1)
7	05-88-5905	K50 x 41mm Slit. Pan Hd. T-20 PT Screw	(1)
8	05-88-5927	K50 x 63mm Slit. Pan Hd. T-20 PT Screw	(2)
9	06-42-0800	Woodruff Key	(1)
10	06-42-2000	Woodruff Key	(1)
12	06-75-0500	Hex Hd. Cap Screw	(2)
13	06-75-3150	1/4-20 x 1" L.H. Skt. Hd. Cap Screw	(1)
14	06-82-7261	6-19 x .687 Slotted Plastite T-15 Screw	(4)
15	06-82-7276	6-19 x 1.00 Slotted Plastite T-15 Screw	(2)
18	12-99-2120	Service Nameplate	(1)
19	14-72-0110	Right Angle Drive Assembly	(1)
20	16-01-0720	Armature Assembly	(1)
21	18-01-2120	Field Assembly	(1)
22	22-20-0860	Brush Tube	(2)
23	22-32-0400	Brush Spring Clip	(2)
24	22-56-0975	Connector Block	(1)
25	23-66-0023	Service Switch Assembly	(1)
26	28-14-1922	Gearcase	(1)
27	28-28-0601	Diaphragm	(1)
28	31-05-0719	Baffle	(1)
29	-----	Connector Block Cover	(1)
30	31-44-0718	Right Handle Halve	(1)
31	31-44-0719	Left Handle Halve	(1)
32	31-50-0019	Motor Housing	(1)
33	32-40-1251	Intermediate Gear	(1)
34	32-75-2011	Spindle Gear	(1)
35	34-60-1200	External Retaining Ring	(1)
36	34-80-2500	Retaining Ring	(1)
37	36-66-2711	Intermediate Pinion	(1)
38	38-50-5475	Spindle	(1)
39	40-50-8840	Brush Spring	(2)
40	42-90-0170	Reversible Female Coupling	(1)
41	45-22-0120	Attachment Sleeve Assembly	(1)

FIG.	PART NO.	DESCRIPTION OF PART	NO. REQ.
42	45-24-0720	Lock Off Lever	(1)
43	45-88-0601	Tool Retaining Washer	(1)
45	48-66-1360	1/2" Chuck	(1)
46	22-18-0719	Carbon Brush Assembly-Red	(1)
47	22-18-1719	Carbon Brush Assembly-Black	(1)
48	23-94-0016	Leadwire Assembly-Black	(1)
49	23-94-0015	Leadwire Assembly-Red	(1)
50	43-62-0885	Side Handle	(1)
51	43-62-1170	Side Handle Extension	(1)
	25-82-0130	Handle Ring (Not Shown)	(1)
	49-96-0070	5/32" Hex Key (Not Shown)	(1)
	49-96-4060	9/16" and 11/16" Wrench (Not Shown)	(1)
	48-66-3280	Chuck Key (Not Shown)	(1)

LUBRICATION

Place 3-3/4 oz. of type "A" grease, No. 49-08-0800, near ball bearing (1) in the gearcase (26).

NOTES:

Seal side of bearing (4) to face armature (20).

Stamped arrows (>>) on field casing (21) to face armature fan.

Needle bearings (5 and 6) are to be pressed from the open end flush to ±.005 to face of bearing boss of diaphragm (21).

Remove brush tubes (22) prior to removing armature assembly (20) from motor housing (32).

Install brush tubes (22) into motor housing (32) only after armature assembly (20) has been secured into motor housing (32).

MILWAUKEE ELECTRIC TOOL CORPORATION
13135 W. LISBON RD., BROOKFIELD, WI 53005
Drwg. 2

WIRING INSTRUCTIONS

POSITION WIRES ON SWITCH TABS AND SOLDER, AS SHOWN.

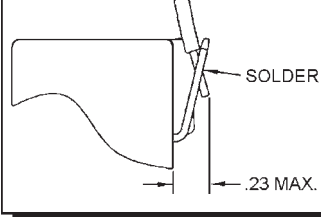

Carbon brush wires #1 and #2 are to be positioned with the wire crimps in the traps.

Route carbon brush wires #1 and #2 into wire traps, as shown.

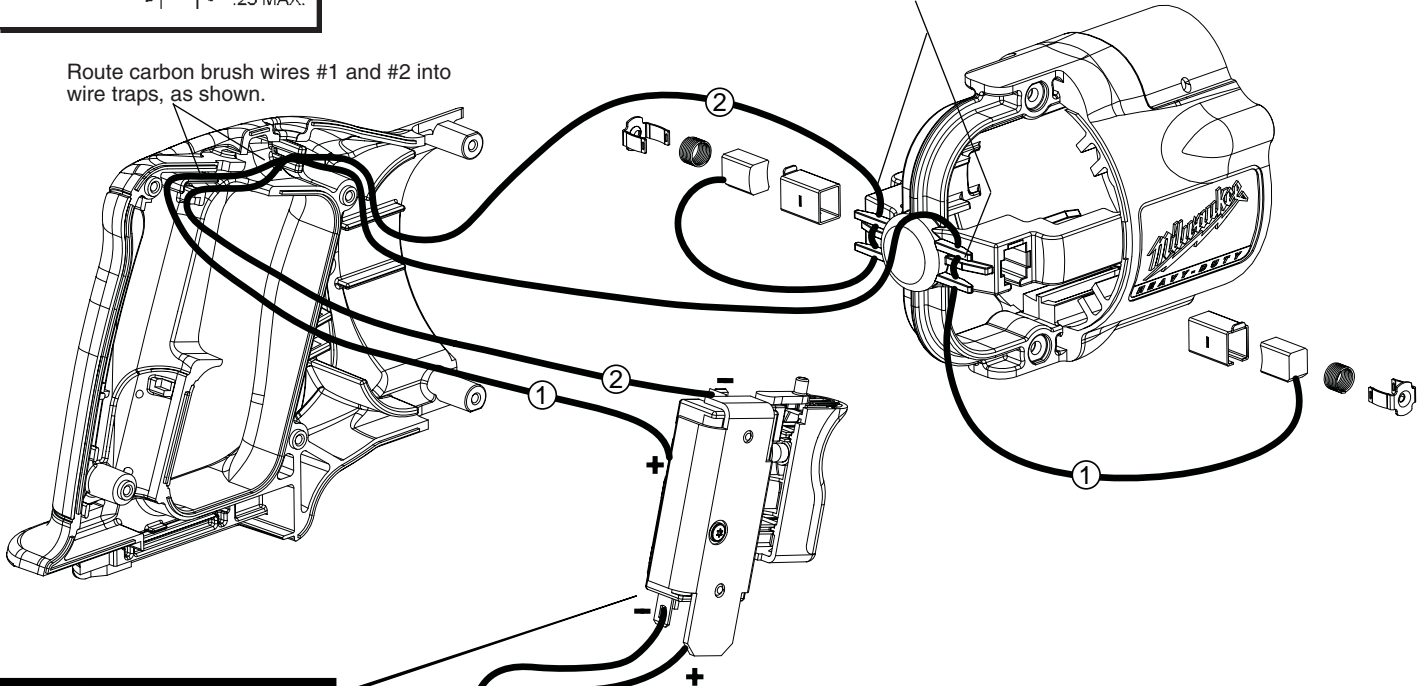

⚠ WARNING

SWITCH POLARITY SENSITIVE
If wired incorrectly, switch **will be** damaged and destroyed!

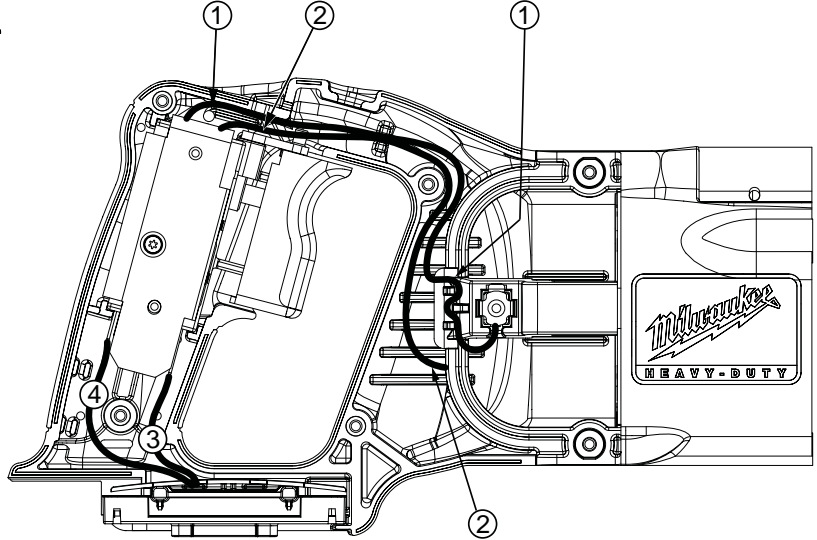
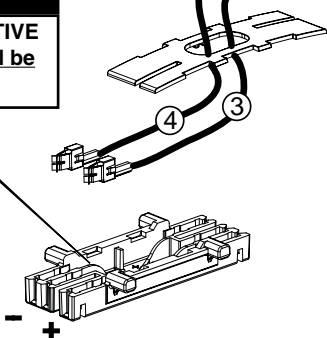

WIRING SPECIFICATIONS

Wire No.	Wire Color	Origin or Gauge	Length	Terminals, Connectors and 1 or 2 End Wire Preparation
1	Red	22-18-0719	-----	Carbon brush assembly.
2	Black	22-18-1719	-----	Carbon brush assembly.
3	Red	23-94-0015	-----	Leadwire assembly.
4	Black	23-94-0016	-----	Leadwire assembly.

TERMINAL DESCRIPTION

Code	Part No.	Qty.

BULK LEAD WIRE - BULLETIN NO. 58-01-0003