

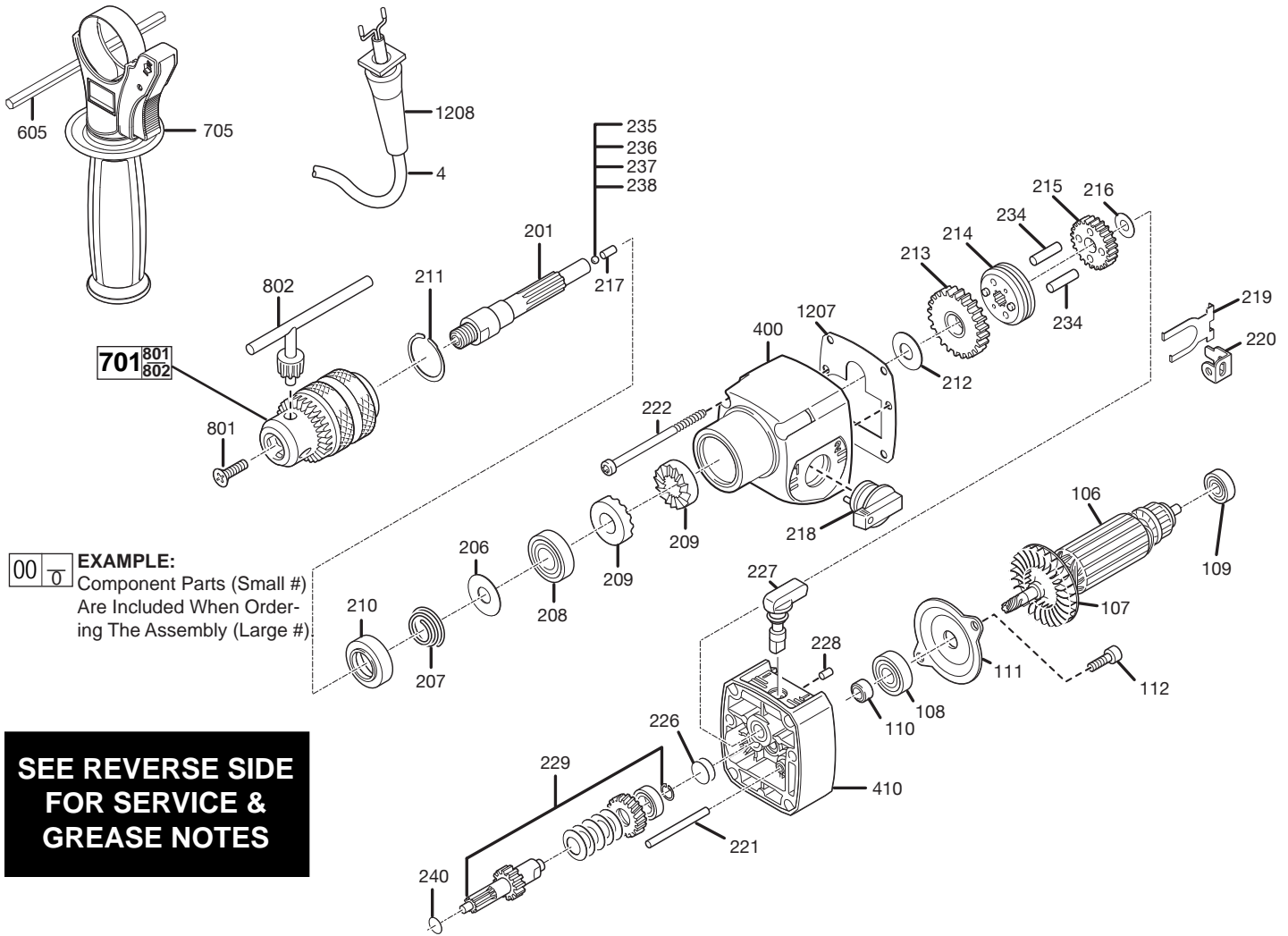

SERVICE PARTS LIST

SPECIFY CATALOG NO. AND SERIAL NO. WHEN ORDERING PARTS		REVISED BULLETIN	DATE
1/2" HAMMER DRILL			Mar. 2010
CATALOG NO. 5380-21	STARTING SERIAL NUMBER	B01A	
		WIRING INSTRUCTION 58-01-5380	



EXAMPLE:
Component Parts (Small #)
Are Included When Ordering
The Assembly (Large #)

**SEE REVERSE SIDE
FOR SERVICE &
GREASE NOTES**

FIG.	PART NO.	DESCRIPTION OF PART	NO. REQ.	FIG.	PART NO.	DESCRIPTION OF PART	NO. REQ.
4	22-64-0490	Cordset	1	219	40-50-8355	Retaining Spring	1
106	16-07-0220	Armature	1	220	42-70-0790	Shifting Clip	1
107	22-84-0940	Fan	1	221	44-60-1470	Pin	1
108	02-04-1825	Ball Bearing	1	222	05-81-0190	Screw	4
109	02-04-0064	Ball Bearing	1	226	45-88-0315	Washer	2
110	45-22-0055	Sleeve	1	227	44-40-0130	Switch Lever	1
111	42-92-0070	Bearing Cover	1	228	44-60-1500	Pin	1
112	05-81-0960	Screw	2	229	32-60-0110	Reduction Gear	1
201	38-50-0042	Spindle	1	234	44-60-1475	Pin	2
206	45-88-8295	Washer	1	235	02-02-0110	Ball 4.0 mm	1
207	40-50-8890	Spring	1	236	02-02-0115	Ball 3.8 mm	1
208	02-04-1830	Ball Bearing	1	237	02-02-0125	Ball 3.6 mm	1
209	44-84-0295	Ratchet	2	238	02-02-0105	Ball 3.4 mm	1
210	44-90-0004	Seal Ring	1	240	45-88-8345	Thrust Washer	1
211	44-90-0365	Snap Ring	1	400	31-40-0160	Gear Case	1
212	45-88-1300	Washer	1	410	28-28-0030	Diaphragm Assembly	1
213	32-75-1220	Spindle Gear	1	605	43-46-0172	Depth Gage	1
214	44-90-4505	Shift Ring	1	701	48-66-5185	1/2 in. Chuck and Key	1
215	32-75-0070	Spindle Gear	1	705	49-15-5300	Side Handle	1
216	45-88-8335	Washer	1	801	05-80-0470	Locking Screw	1
217	44-60-1490	Pin	1	802	48-66-2110	Chuck Key	1
218	44-10-0095	Shift Lever	1	1207	43-44-0345	Gasket	1
				1208	44-76-0290	Cord Strain Relief	1

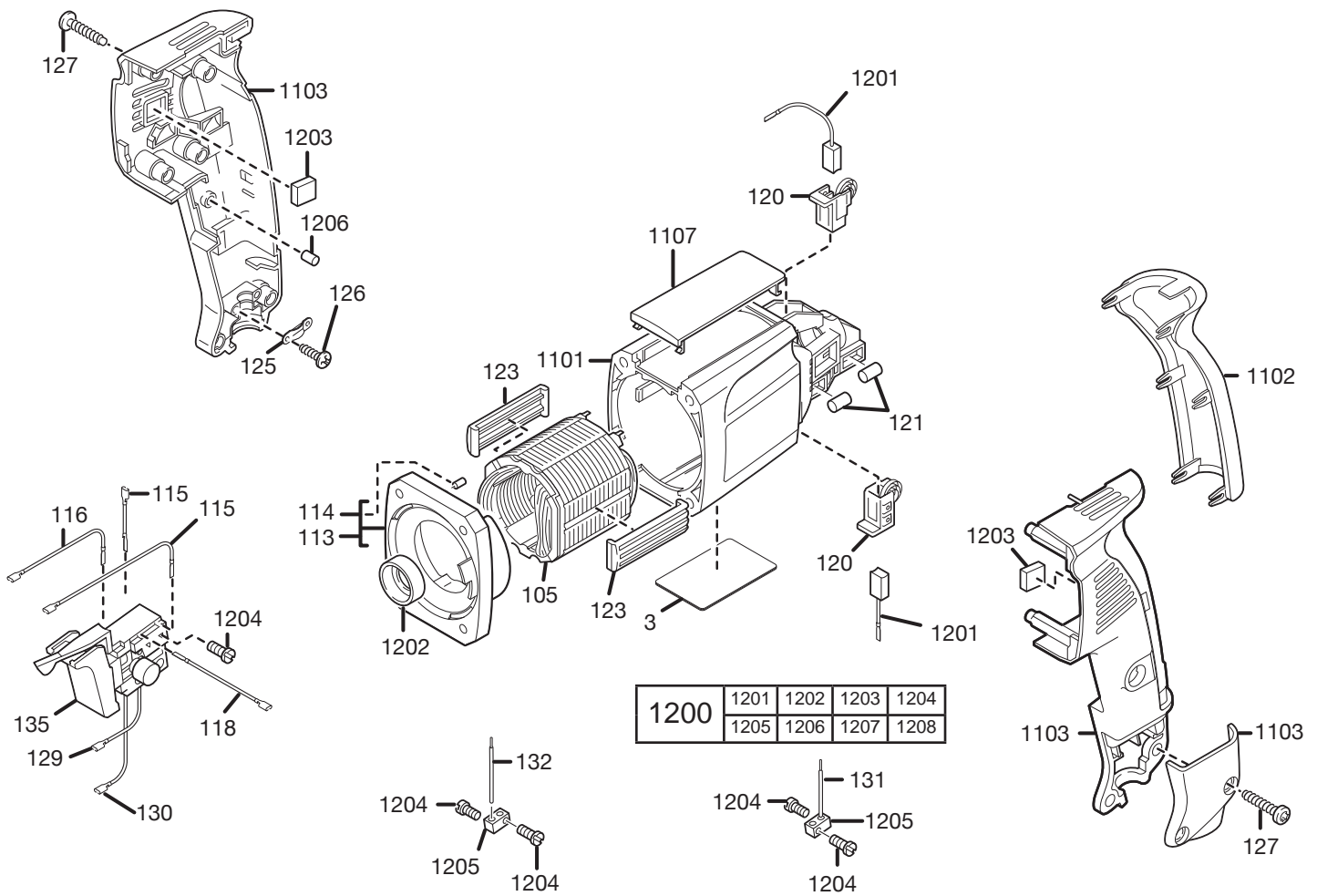

FIG.	PART NO.	DESCRIPTION OF PART	NO. REQ.
3	12-20-5380	Service Nameplate	1
105	18-07-0180	Field	1
113	42-14-0430	Air Deflection Ring	1
114	45-30-0210	Slug	4
115	23-94-6710	Wire	2
116	23-94-6715	Wire	1
118	23-94-6720	Wire	1
120	22-20-0232	Brush Holder	2
121	44-60-0915	Roller Pin	4
123	42-70-0030	Field Centering Clip	2
125	31-17-0240	Cord Clamp	1
126	05-78-0720	Screw	2
127	05-78-0715	Screw	6
129	23-94-6730	Wire	1
130	23-94-6735	Wire	1

FIG.	PART NO.	DESCRIPTION OF PART	NO. REQ.
131	23-94-6745	Wire	1
132	23-94-6740	Wire	1
135	23-66-0410	Switch	1
1101	31-50-0165	Motor Housing	1
1102	44-52-0030	Handle Cushion	1
1103	14-38-0110	Housing Assembly	1
1107	31-15-0160	Cover	1
1200	14-46-0090	Maintenance Set	1
1201	22-16-0025	Carbon Brush	1
1202	45-22-0540	Rubber Sleeve	1
1203	43-87-0085	Isolation Block	2
1204	05-81-0932	Screw	6
1205	42-86-0150	Connector	2
1206	45-30-0055	Slug	1

SERVICE PARTS LIST

Service Notes

218, 227

Lubricate O-ring(s) on shifting levers (218 and 227) prior to assembly.

201, 235-238

The correct size ball (235-238) must be chosen to properly shim out the end play in the spindle (201). Spindle is to have a small amount of end play without being tight.

801

Apply a drop of Blue Loctite® to locking screw (801) prior to installing into spindle.

229

Do not place clutch assembly (229) in solvent solution. Wipe off with a clean dry cloth.

Greasing Instructions

Type "P" (49-08-4250)

Type "U" (49-08-0150)

When servicing, remove 90-95% of the existing grease prior to installing Type 'P' grease. Original grease maybe similar in color but not compatible with 'P'.

1. Coat ratchets (209) with 1/16 oz. of Type "U" grease, No. 49-08-0150.
2. Coat spindle spline (201), pin (217) and ball (235-238) with 1/16 oz. of Type "P" grease, No. 49-08-4250.
3. Place 1/8 oz. of Type "P" grease, No. 49-08-4250, in first reduction gear cavity in diaphragm (410).
4. Lubricate gear assembly (parts 212, 213, 214, 215, 216, 219, 220, 221, 226, 229, 234, and 240) using 1/4 oz. of Type "P" grease, No. 49-08-4250.

Total amount of lubrication: approximately 1/2 oz.

